

KF45-2G

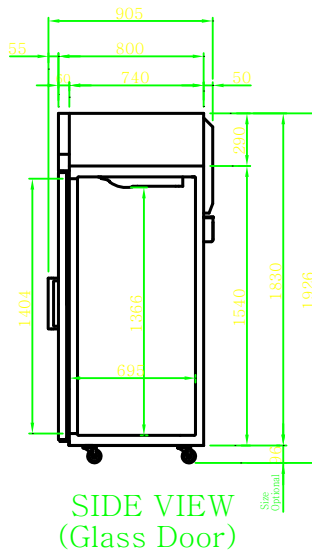
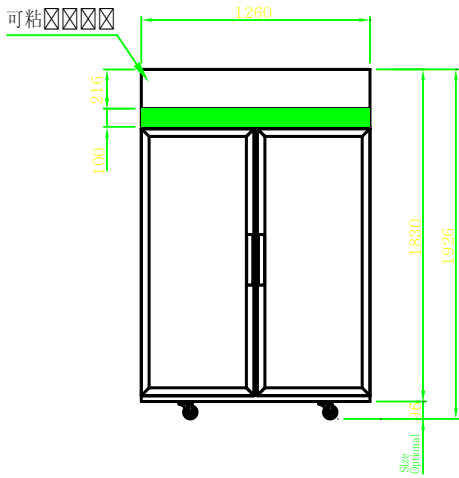
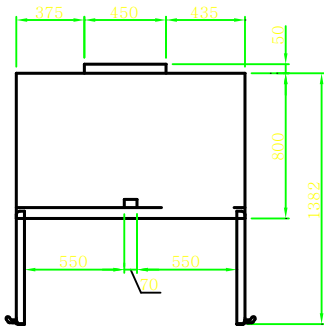

1	Classification	(Freezer)
2	外形尺寸 Cabinet Dimensions	260x800x1926
3	Capacity(Liters)	1215
4	Inner Temperature	-21 °C~-12 °C
5	Doors	2
6	of shelves	6
7	Refrigerant	R-404a
8	Compressor(HP)	1 1/4
9	Cooling Type	Fan cooling type)
10	control type	Digital)
11	Insulation Type	(Polyurethane) Cyclopentane+CFC Free
12	Amps(A)	8
13	Voltage(V/Hz/Ph)	220/50/1
14	Power(w)	976
15	Weight(kg)	170

REFRIGERATOR MANUFACTURER
Turbo air
www.turboairchina.com

Series	Model	Model Name	DATE	CODE NO	SCALE
					1/1
K	KF45-2G	2 Door Top Mount Glass Door-Freezer	14.01.01	TUCQ-024	UNIT mm