

TCBE-82SDR

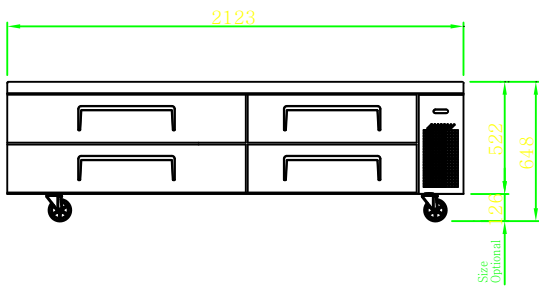

1	Classification	(Refrigerator)
2	Cabinet Dimensions	2123x744x649
3	Capacity(Liters)	538
4	Inner Temperature	-1 °C~8 °C
5	Drawer	4
6	Refrigerant	R-134a
7	Compressor(HP)	1/4
8	Cooling Type	Fan cooling type
9	control type	(Thermostat)
10	Insulation Type	(Polyurethane) Cyclopentane+CFC Free
11	Amps(A)	3.7
12	Voltage(V/Hz/Ph)	220/50/1
13	Power(w)	366
14	Weight(kg)	186

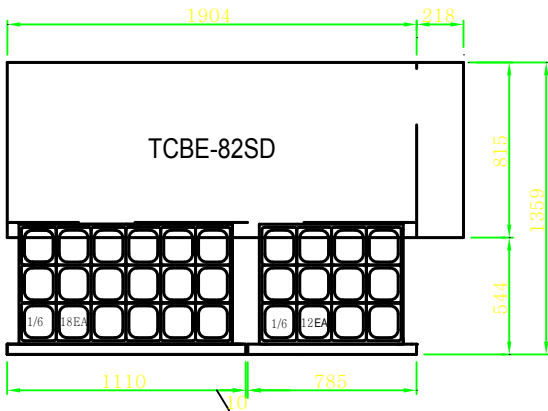
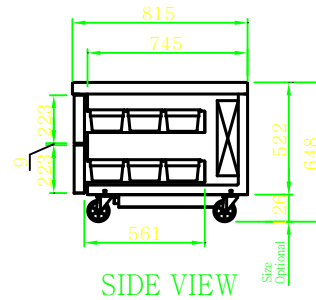

REFRIGERATOR MANUFACTURER
Turbo air
www.turboairchina.com

Series	K	Model	TCBE -82SDR	Model Name	2 Dower Chef Bases-Refrigerator	DATE	14.01.01	CODE NO	TUCQ-070	SCALE
	1									
										UNIT
										mm

A B C D E F G H I J K L M N O P Q R S T U V W X Y Z

A B C D E F G H I J K L M N O P Q R S T U V W X Y Z