

# TCBE-96SDR

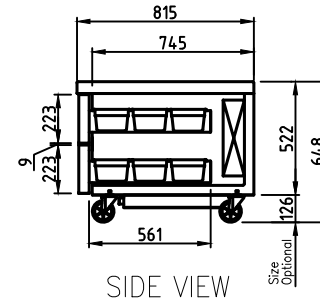
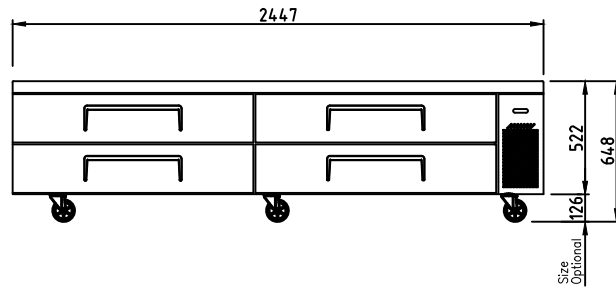
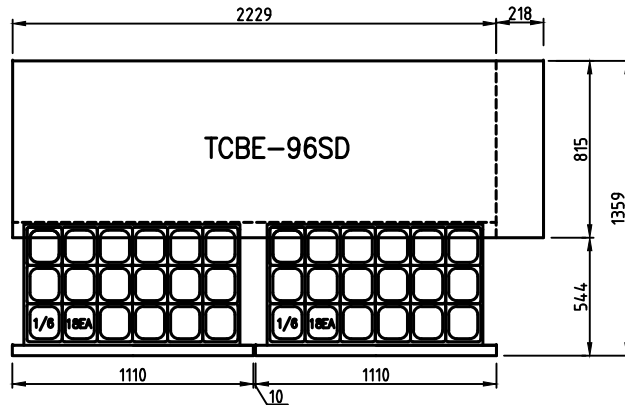

1	Classification	Refrigerator
2	Cabinet Dimensions	2447x744x649
3	Capacity(Liters)	651
4	Inner Temperature	1°C~8°C
5	Drawer	4
6	Refrigerant	R-134a
7	Compressor(HP)	1/4
8	Cooling Type	( Fan cooling type)
9	control type	( Thermostat )
10	Insulation Type	( Polyurethane) Cyclopentane+CFC Free
11	Amps(A)	3.7
12	Voltage(V/Hz/Ph)	220/50/1
13	Power(w)	366
14	Weight(kg)	219

A B C D E F G H I J K L M N O P Q R S T U V W X Y Z

REFRIGERATOR MANUFACTURER  
**Turbo air**  
www.turboairchina.com

Series	Model	Model Name	DATE	CODE NO	SCALE 1/1
K	TCBE-96SDR	2 Drawer Chef Bases-Refrigerator	14.01.01	TUCQ-071	UNIT mm

AZ-594X720